

**Features**

- **Noise Figure : 3.0 dB (typ)**
- Unconditionally Stable at all temperatures
- Internally Regulated DC Voltage
- 50 Ohm Matched Input/Output
- Field Replaceable 3.5mm SMA connectors
- Excellent Group Delay and Phase Linearity
- 0.009 inches diameter RF In/Out feed through
- Operating Temp. -55 C to +85 C
- 3 Year Warranty

**Options**

- **Optimized Performance over Selected Bandwidth**
- Internally DC Block Input (Output DC Block Standard)
- Hermetically Sealed Package
- Improved Gain Flatness
- Improved IN and OUT VSWR
- Gain and Phase matching
- Lower Noise Figure



**Specifications (23 °C)**

Parameter	Min	Typ	Max	Units
Frequency Range	6.5	-	9.5	GHz
Noise Figure*	-	3	3.5	dB
Gain	29	31	-	dB
Gain Flatness (+/-)	-	± 1.0	± 1.5	dB
P1 Output Power	+23	+24	-	dBm
Input VSWR	-	-	2.5:1	
Output VSWR	-	-	2.5:1	
Operating Temperature	-55	-	+85	°C
Non-Operating Temp Range	-65	-	+85	°C
RF Input Power (no-damage)	-	-	+13	dBm
Humidity (non-condensing)	-	-	95	%
Voltage	+9	+12	+12	VDC
Current	-	225		mA
Input Impedance	50			Ohms
RF Connector	3.5mm SMA - Female			
Dimensions	29.9 x 18.7 x 7.6			mm

\*\*\* IMPORTANT: UNIT REQUIRES HEATSINK \*\*\*

\* Noise Source used for measurement from 0.01 to 26.5 GHz is HP346C .  
NF Uncertainty (approx. 0. 1dB). 0.05 dB due to ENR of HP 346C; and 0.05 dB, due to the gain modulation of the unit, caused by the HP 346C source impedance change in the ON and OFF state.

**Typical Data**

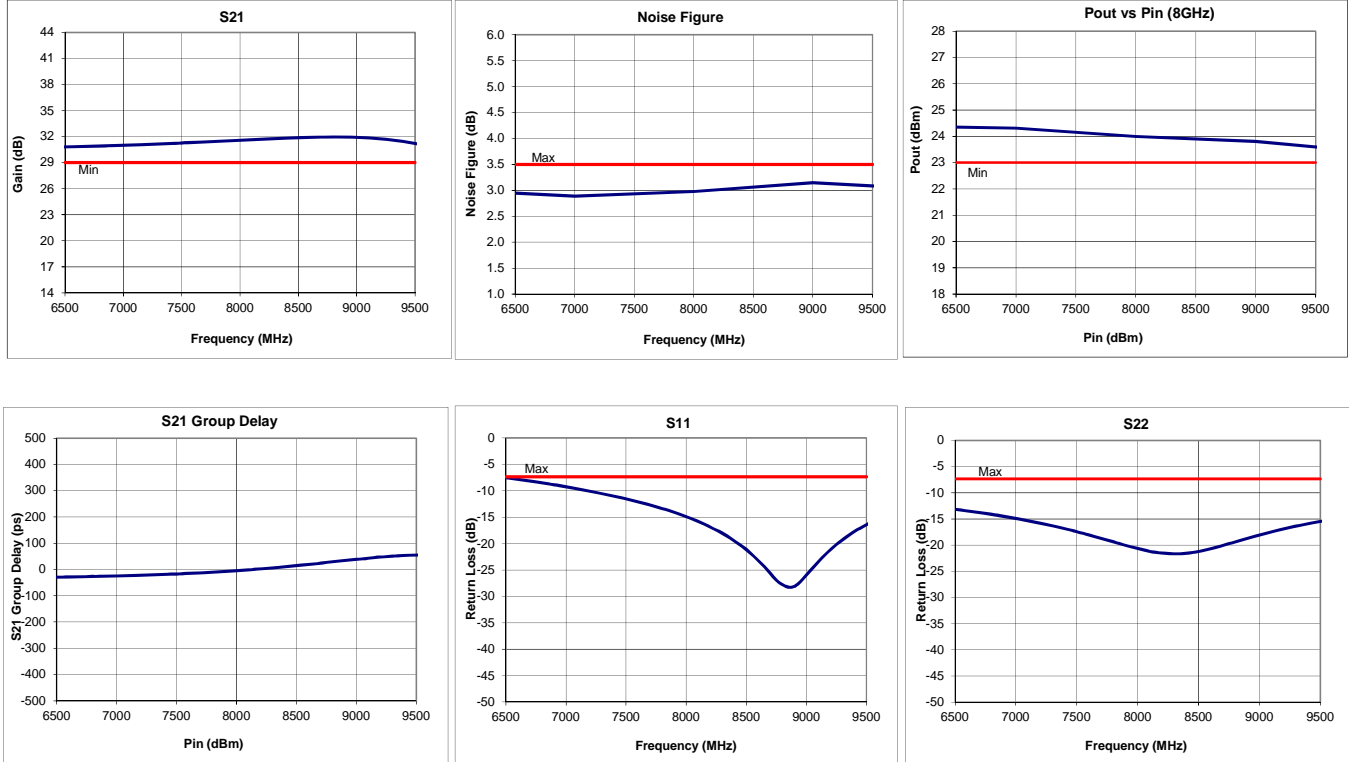



Approx. Actual Size



**Mounting Drawing**

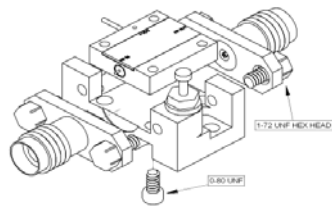

**Drop In**

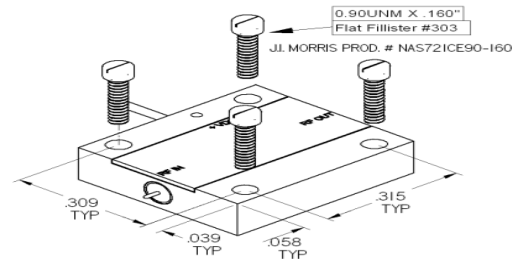

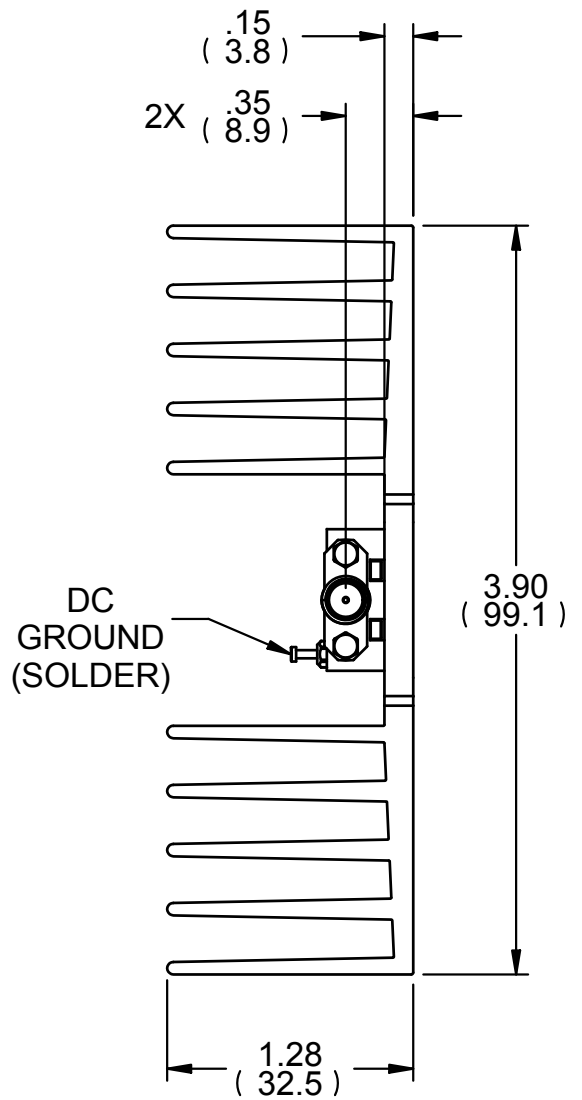
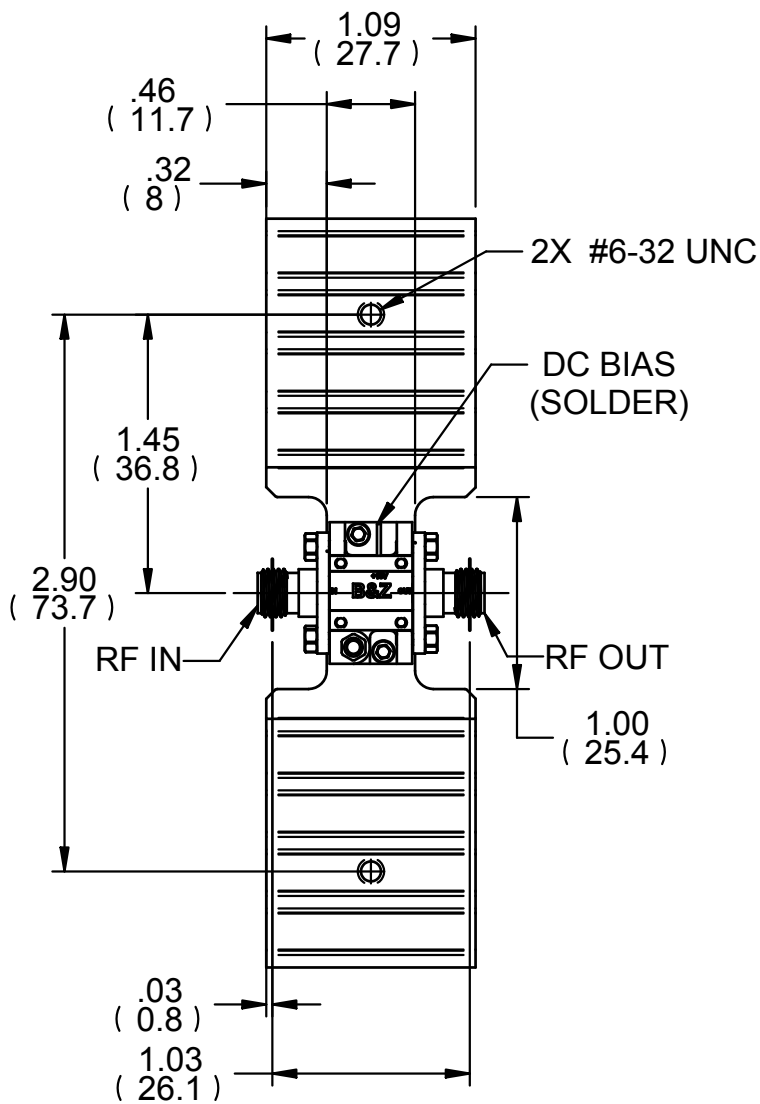

**NOTES:**

1. HEATSINK SURFACE AREA 35.14 SQ. INCHES
2. HEATSINK MATERIAL: ALUMINUM ALLOY
3. APPROXIMATE TEMPERATURE RISE IS 6.5°C/W IN STILL AIR.

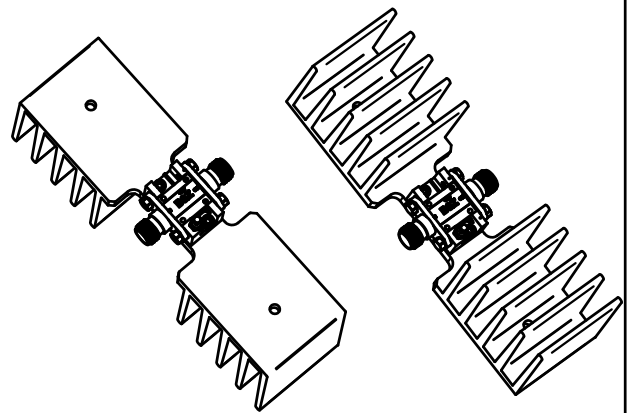

**B&Z**  
TECHNOLOGIES

SIZE  
**A**

**OUTLINE,  
STD. AMPLIFIER ON HEATSINK**

**100169**

SCALE

REF. FILE NAME: 100169\_A Outline, Std Amplifier on Heatsink

SHEET 1 OF 1

REV. **A**