

**Features**

- **Noise Figure  $\leq 2.5$  dB**
- Unconditionally Stable at all temperatures
- Internally Regulated DC Voltage
- 50 Ohm Matched Input/Output
- Field Replaceable SMA connectors
- Excellent Group Delay and Phase Linearity
- 0.009 inches diameter RF In/Out feed through
- Operating Temp. -55 C to 85 C
- 3 Year Warranty

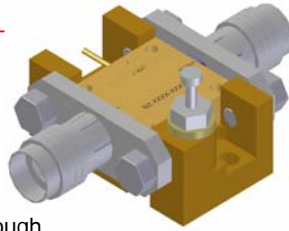

**Specifications (23 °C)**

Parameter	Min	Typ	Max	
Frequency Range	0.5	-	10	GHz
Noise Figure *			2.4	dB
Gain	20		-	dB
Gain Flatness	-		$\pm 0.5$	dB
P1dB Output Power**	18			dBm
Input VSWR	-		2.0:1	
Output VSWR	-		2.0:1	
Operating Temperature	-55	-	+85	°C
Voltage ***	+14.5	-	+15.5	V
Current	-	155	185	mA

**Options**

- **Optimized Performance over Selected Bandwidth**
- Internally DC Block Input (Output DC Block Standard)
- Hermetically Sealed Package
- Improved Gain Flatness  $\pm 1.0$  dB Max
- Improved IN and OUT VSWR
- Gain and Phase matching
- Internal D.C. Voltage regulation

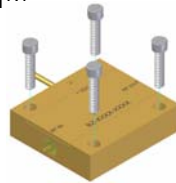

\* Noise Sources used for measurement: 0.5- 10 GHz: HP346A N.F. Uncertainty (approx. 0.15 dB). 0.1 dB due to ENR of HP 346A, and 0.05 dB, due to gain modulation of the unit, caused by the HP 346A source impedance change in the ON and OFF state.  
Noise Figures and other parameters degrade below 500 MHz.

\*\*IMP: UNIT REQUIRES HEAT SINK.

\*\*\* Input +15V with Internal D.C. voltage Regulation available

**Performance Graphs**

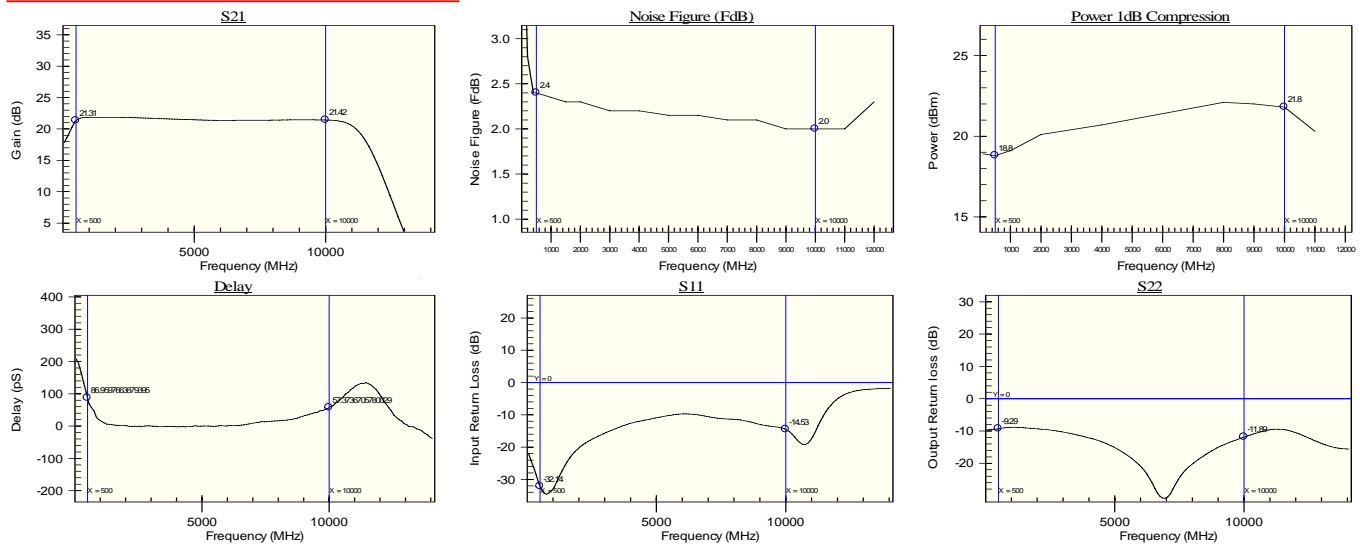

**Outline Drawing**

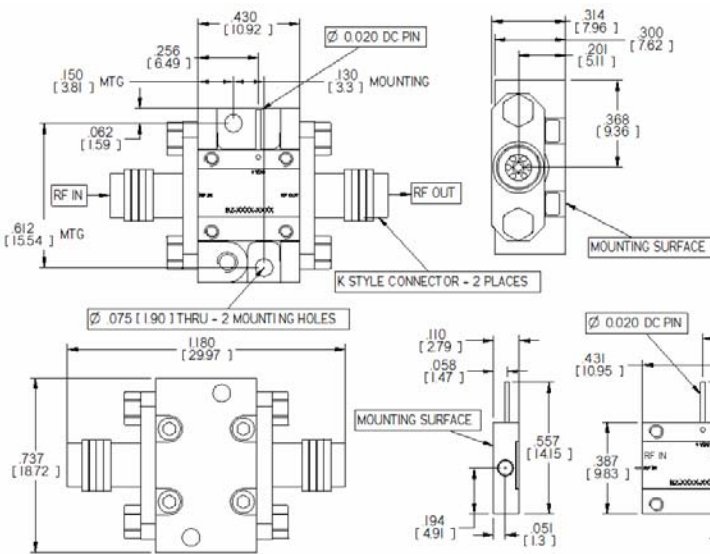

**Mounting Drawing**

