

#### Features

- **Noise Figure  $\leq 5.0$  dB Measured**
- Unconditionally Stable at all temperatures
- Internally Regulated DC Voltage
- 50 Ohm Matched Input/Output
- Field Replaceable SMA connectors
- Excellent Group Delay and Phase Linearity
- 0.009 inches diameter RF In/Out feed through
- 3 Year Warranty

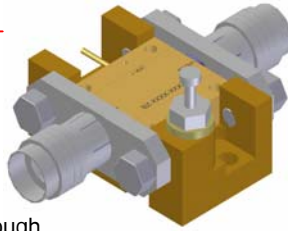

#### Specifications (23 °C)

Parameter	Min	Typ	Max	
Frequency Range	0.5	-	18	GHz
Noise Figure *			5.0	dB
Gain	10	11	-	dB
Gain Flatness	-		$\pm 0.5$	dB
P1dB Output Power	10	11	-	dBm
Input VSWR	-		1.8:1	
Output VSWR	-		1.8:1	
Operating Temperature	-55	-	+85	°C
Voltage	+12	-	+15	V
Current	-	90	110	mA

#### Options

- **Optimized Performance over Selected Bandwidth**
- Internally DC Block Input (Output DC Block Standard)
- Hermetically Sealed Package
- Gain and Phase matching
- Extended bandwidth to 100 MHz.

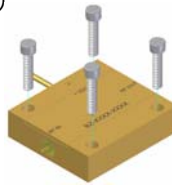

\* Noise Source used for measurement: 0.1 – 18 GHz: HP346A, Uncertainty of N.F. (approx. 0.15 dB) .10 db due to ENR of noise source, .05 db due to Gain modulation of the amplifier. Noise Figures increase below 500 MHz

#### Performance Graphs

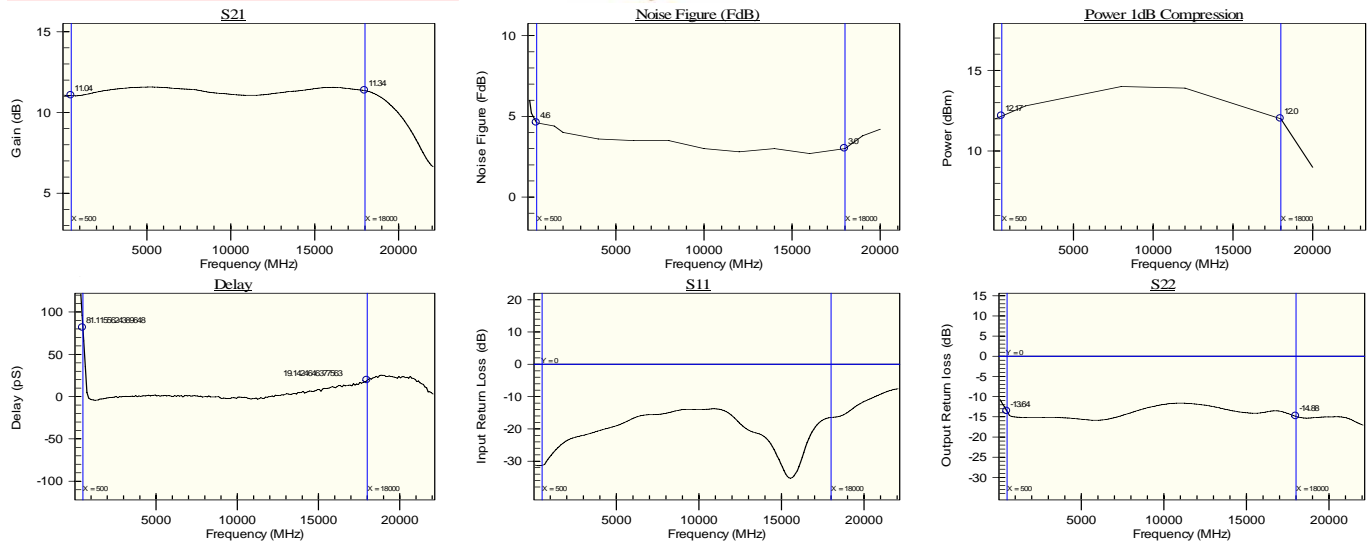

#### Outline Drawing

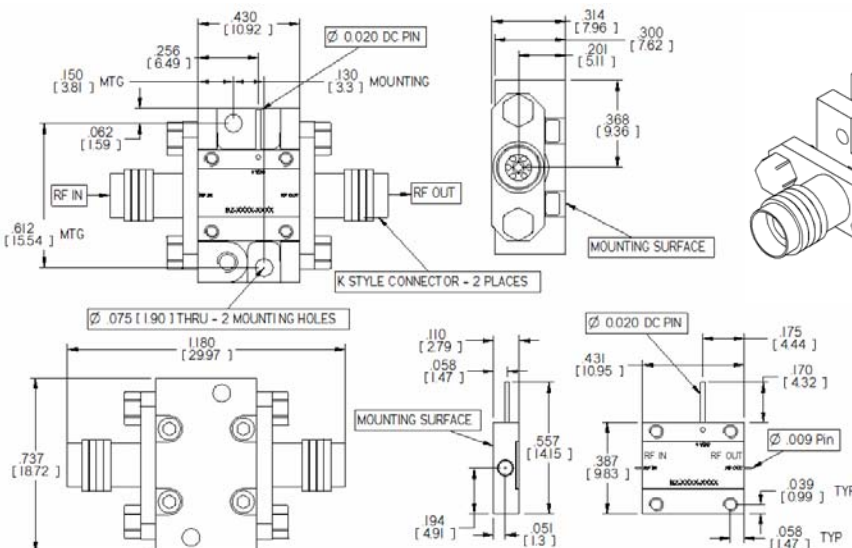

#### Mounting Drawing

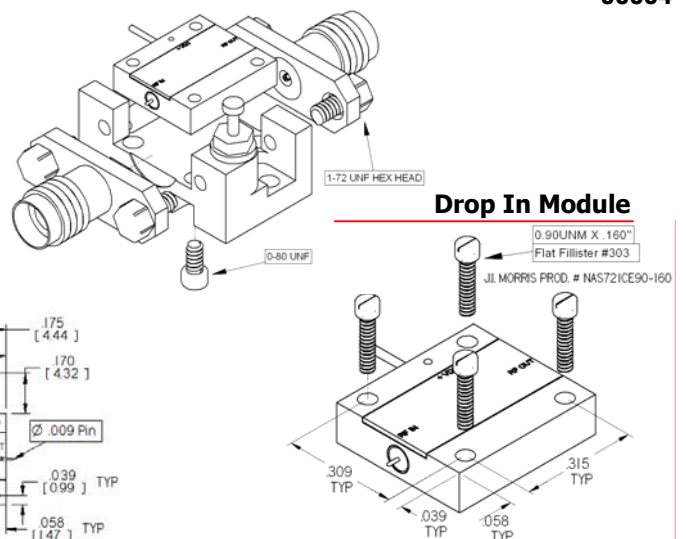

00004