

### Features

- **Noise Figure  $\leq 1.7$  dB**
- Unconditionally Stable at all temperatures
- Internally Regulated DC Voltage
- 50 Ohm Matched Input/Output
- Field Replaceable SMA connectors
- Excellent Group Delay and Phase Linearity
- 0.009 inches diameter RF In/Out feed through
- 3 Year Warranty

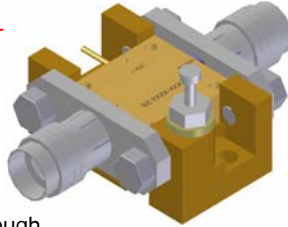

### Specifications (23 °C)

| Parameter              | Min | Typ      | Max       |      |
|------------------------|-----|----------|-----------|------|
| Frequency Range        | 0.1 | -        | 12        | GHz  |
| Noise Figure *         |     |          | 1.7       | dB   |
| Gain                   | 24  | 26       | -         | dB   |
| Gain Flatness          | -   |          | $\pm 1.2$ | dB   |
| P1dB Output Power      | 8   | 10       | -         | dBm  |
| Input VSWR             | -   |          | 2.0:1     |      |
| Output VSWR            | -   |          | 2.0:1     |      |
| Operating Temperature  | -55 | -        | +85       | °C   |
| Third Order Intercept  | 17  | 19       |           | dBm  |
| Second Order Intercept | 26  | 28       |           | dBm  |
| Group Delay2 - 12GHz   |     | $\pm 15$ |           | psec |
| Voltage                | +12 | -        |           | V    |
| Current                | -   | 120      | 155       | mA   |

### Options

- **Optimized Performance over Selected Bandwidth**
- Internally DC Block Input (Output DC Block Standard)
- Hermetically Sealed Package
- Improved Gain Flatness
- High Power Input Protection
- Gain and Phase matching
- Lower Noise Figure (**Cryogenic Temp**)

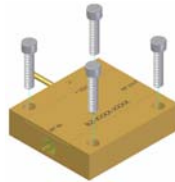

\* Noise Sources used for measurement: 0.1- 12 GHz: HP346A, N.F. Uncertainty (approx. 0.10dB): 0.05dB due to ENR of HP 346A and 0.05dB, due to gain modulation of the unit, caused by the HP 346A source impedance change in the ON and OFF state.  
Noise Figures and other parameters degrade below 500 MHz.  
Noise Figures at **Cryogenic Temp**, not given due to uncertainty of measurement for very low values. Call to discuss.

### Performance Graphs

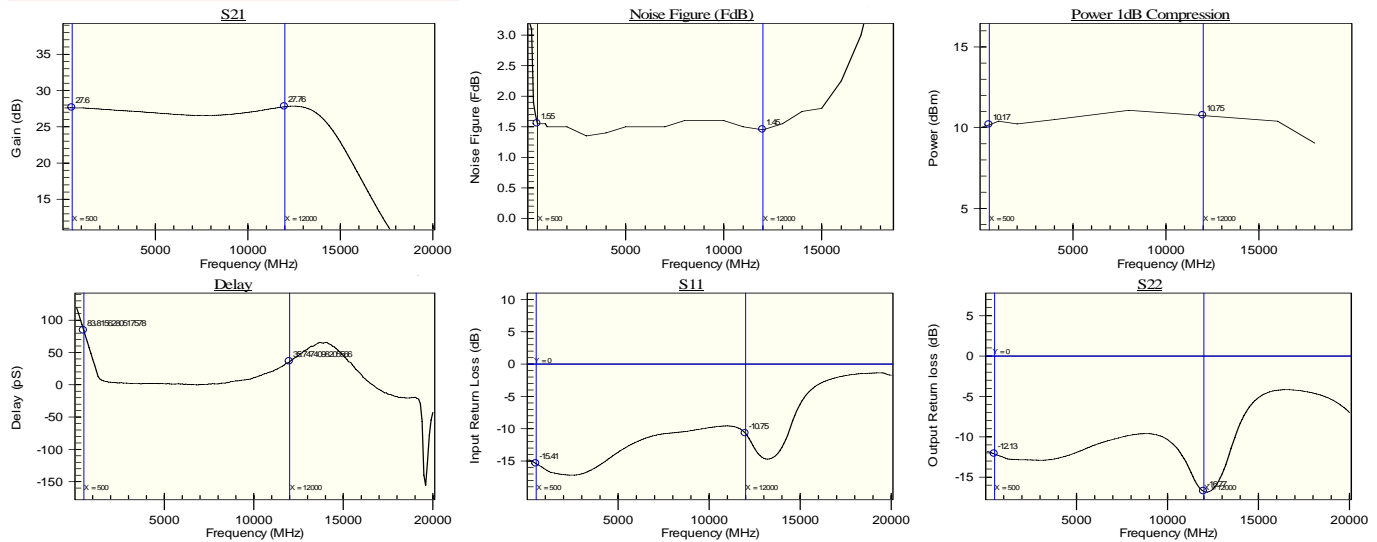

### Outline Drawing

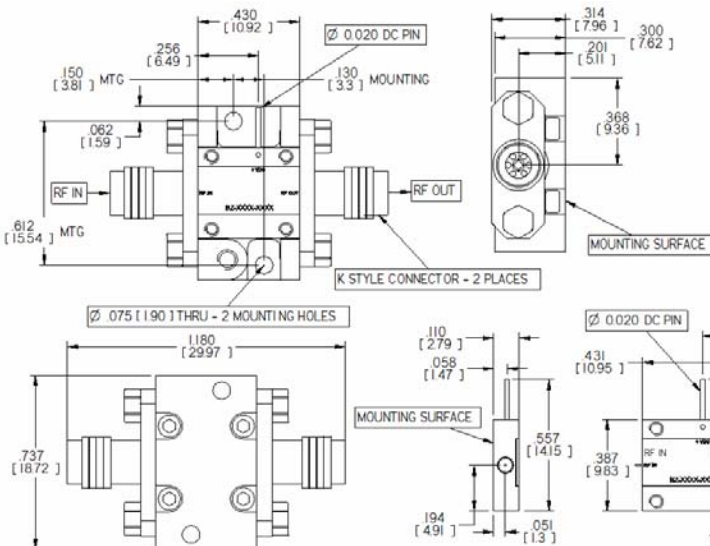

### Mounting Drawing

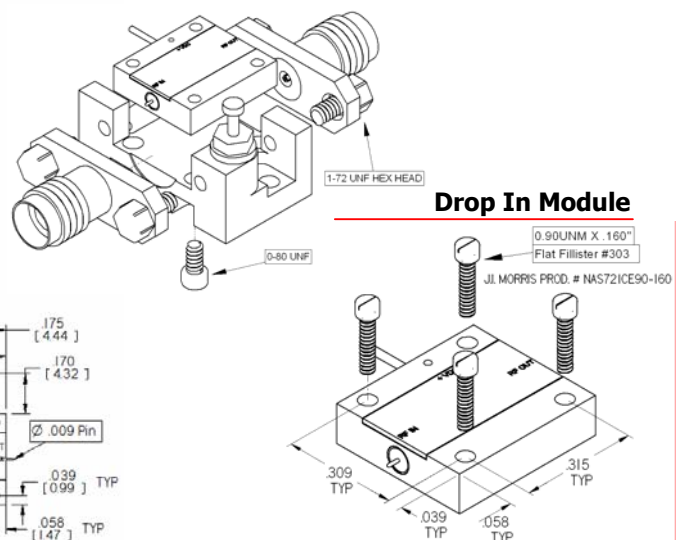

00061